

HELP

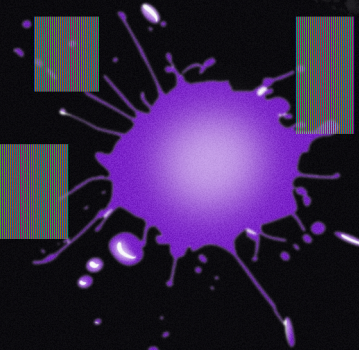

Live like you are going to die...

**BECAUSE YOU ARE.**





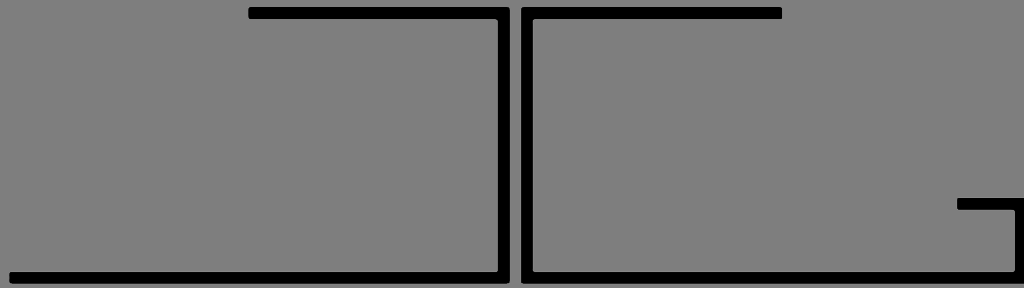

J A S O N G I A N F R A N C H I

**BECAUSE YOU ARE.**

F/W 2023





Woodboard I  
Unusual Decorations





# Woodboard II



*Ideas for the shapes, the volumes,  
the details and the application of  
the patterns*





# Woodboard III

Other ideas and some particular details



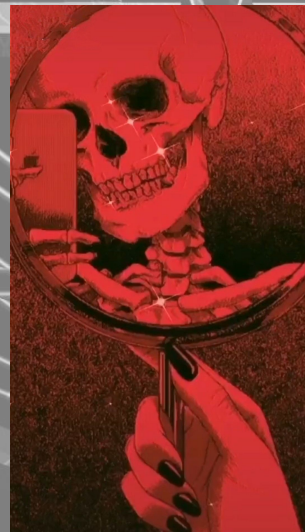
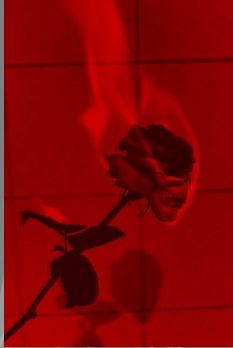

M  
o  
o  
d  
b  
o  
a  
r  
d  
  
I  
V

*Disturbing Pattern*



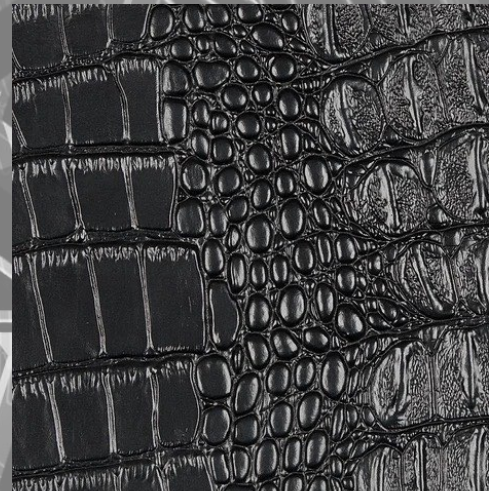
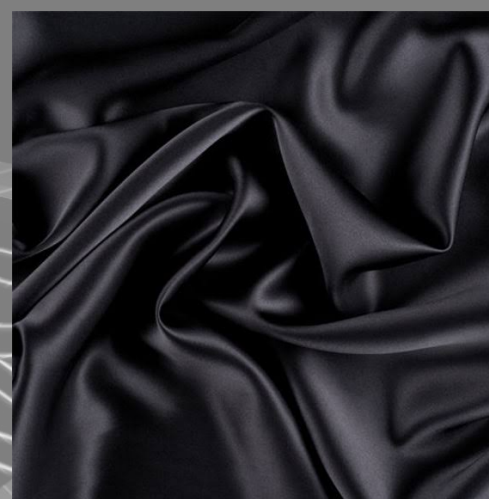

# Woodboard



Ideas for the fabrics:  
P.U., Fake Fur, Velvet and Fake Leather



# Summary Moodboard

Ideas for the creation of a

Family of bags



Handheld Handbag  
Double Handle  
I



Star Shape  
Pouch III



Tote Bag  
V



Shopper Bag II



Canteen Bag IV



# Sketches of the Family

Bags 1

Handheld Handbag  
Double Handle





# Sketches of the Family

Bags 2 & 3

Disco Bags

&

Pouch Bag

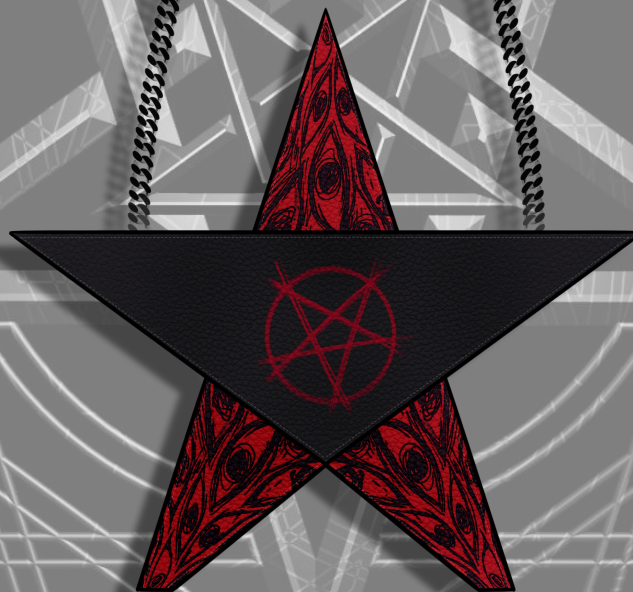
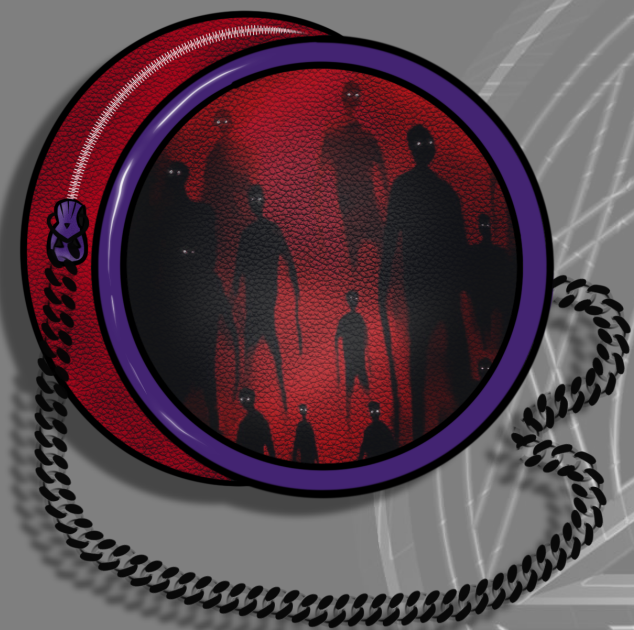



# Sketches of the Family

Bags 4

Tote Bags





# Sketches of the Family

Bags 5

Shoppers

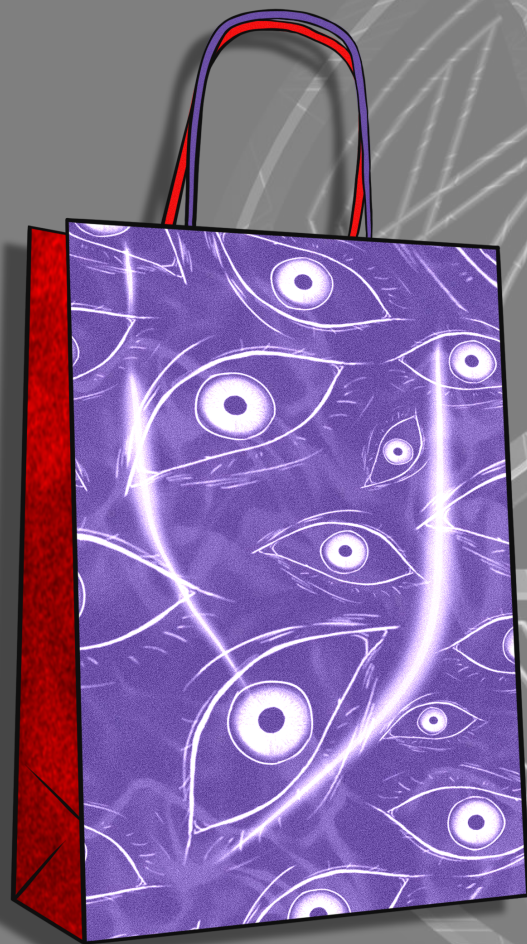



Mom Bag I want to  
develop...





# Measurements & Fabrics...

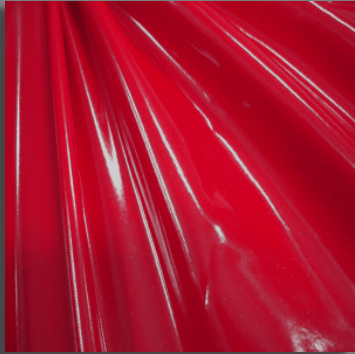

Red Shiny Glossy P.V.C  
Pleather, Red Latex Fabric

100% Polyester



Silky Black Rayon Velvet  
Pre Washed

Weight: 10.5 - 11 oz



Violet Shiny Glossy P.V.C  
Pleather, Violet Latex  
Fabric

100% Polyester





# BAG SPEC SHEET

Date		Product Name		Thread	
Deadline		Group		H/W Finish 1	
Company				H/W Finish 1	
Season					

**A. Front View**

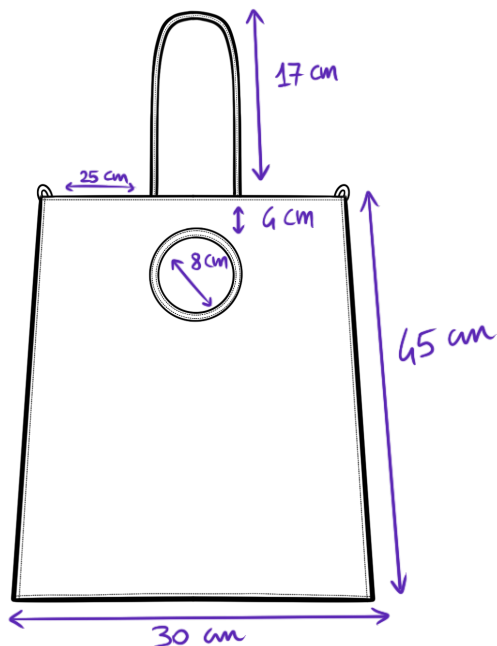

**B. Back View**

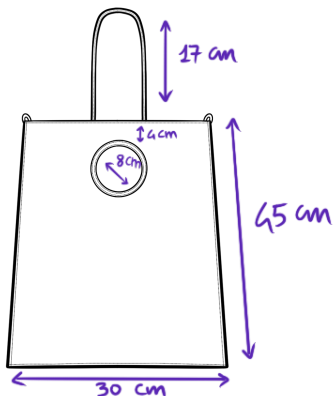

**D. Side View**

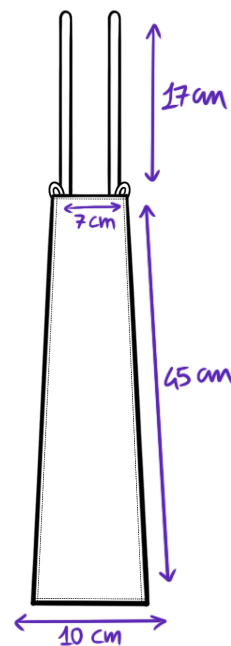

**E. Inside Front**

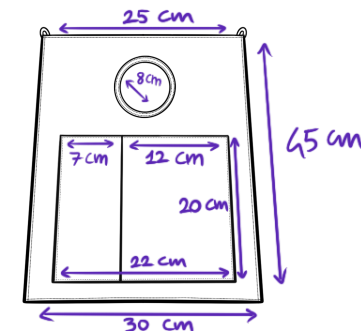

**Shoulder Strap**

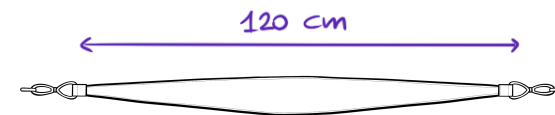

**C. Bottom View**

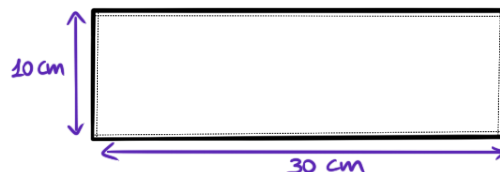

	Material	Description	Notes			
Front Body	Red Shiny P.V.C	A Modified Version of a Shopper.	A	B	C	
Back Body	Red Shiny P.V.C	made with Red Shiny P.V.C for the				
Gusset	Silky Black Rayon Velvet	Front and the external part of the				
Bottom	Silky Black Rayon Velvet	shoulder strap, while the inside of				
Top Handle	Red & Violet Shiny P.V.C	the strap and the sides are in a			D	E
Shoulder Strap	Black Velvet & Red Shiny P.V.C	Silky Black Rayon Velvet.				
Lining	Silky Black Rayon Velvet	There is also a Violet Shiny P.V.C				
Flap Lining	-	tubular in the middle/upper part of				
Side Buckle	-	the bag. The hand straps are both	F			
Closure	-	made with P.V.C.				





G. 2022



G. 2022



G. 2022

Some Sketches of  
the family...



2022



G. 2022











Extra Bag I wanted to realize...





# Measurements & Fabrics...



Eye Print on Velvet



Violet Shiny Glossy PVC  
Pleather, Violet Latex  
Fabric

100% Polyester

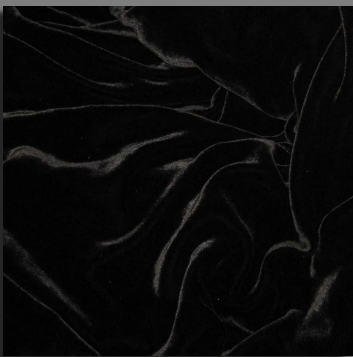

Silky Black Rayon Velvet  
Pre Washed

Weight: 10.5 - 11 oz



Gamba  
Estraibile  
a  
incastro

25 cm

35 cm

45 cm

10 cm



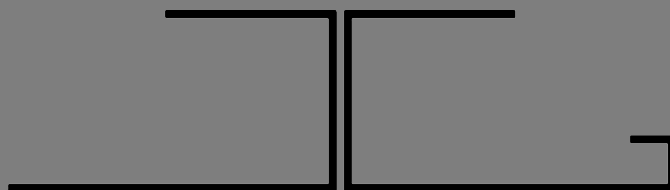

J A S O N   G I A N F R A N C H I

*Per l'occasione collabora con:*

**CONTRADO**

**BECAUSE YOU ARE.**

F/W 2023



# CONTRADO

## STORIA

*Contrado Imaging Ltd è una società fondata nel 2002 con sede a Londra. Contrado è sinonimo di assemblaggio e consegna, effettuati in un unico impianto di produzione. Siamo specializzati nella realizzazione di prodotti personalizzati on demand di qualità. Il servizio consente ai creativi di vendere arte, costruire marchi, offrire prodotti unici e offre ai consumatori la possibilità di trovare prodotti di design esclusivi e di eccezionale qualità. Ogni ordine è accuratamente realizzato a mano esclusivamente presso la nostra struttura, e per la maggior parte degli articoli entro 24 ore.*

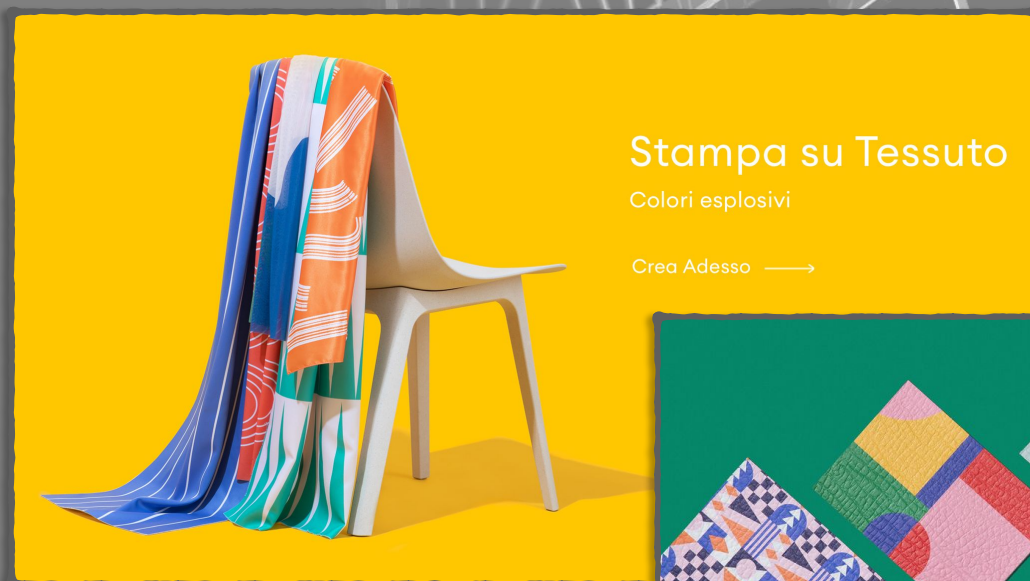



# CONTRADO

## MISSIONE

*La missione di Contrado è facilitare la creatività degli altri e cambiare il modo in cui la gente acquista articoli, mettendo in comunicazione designer e acquirenti con il nostro sistema di produzione on demand.*

*Sviluppiamo in maniera continua nuovi prodotti perché amiamo farlo. Contrado crea, affina e migliora ogni prodotto per dare risultati di qualità. I nostri valori ci spingono a provare le cose, essere creativi, essere utili agli altri e godere del successo con tutti.*





## RECYCLE

In qualità di produttori di stampa on-demand dal 2002, abbiamo guidato il settore nella produzione sostenibile, in tempi di consegna efficienti e nell'eliminazione degli sprechi a tutti i livelli. In veste di produttori, abbiamo anche la responsabilità, di mantenere i prodotti che produciamo lontani dalle discariche. Contrado riconosce l'importanza della sostenibilità e rispetto del medio ambiente, ed ha implementato un sistema di stampa che utilizza inchiostri naturali a base di acqua. Questo significa che tutte le stampe realizzate da Contrado non contengono agenti chimici o solventi. Il nostro stabilimento produttivo ha adottato tutte le precauzioni tecnologiche produttive e di smaltimento dei rifiuti, riducendo al minimo l'impatto ambientale.



# RE:CONTRADO (V.)

Per riciclare qualcosa fatto e assemblato da Contrado





# LAVORAZIONE

Contrado produce 6 tipologie di Velluto diverse.

- 1) Velluto 280 gsm
- 2) Velluto Telato
- 3) Velluto Crushed
- 4) Velluto Chichi
- 5) Velluto Marmorizzato
- 6) Velluto Felpato



Velluto 280 gsm



Velluto Crushed



Velluto Felpato



Velluto Chichi



Velluto Marmorizzato



Velluto Telato



## Velluto scelto dal Brand: Il Velluto Marmorizzato

Elegante, lucido e veramente sontuoso, il nostro Velluto da 371gr/m<sup>2</sup> si presta facilmente a numerosissimi utilizzi. Realizzato con un intreccio di fibre lucide in base poliestere, il velluto può essere personalizzato con qualsiasi design ed essere utilizzato per abbigliamento e arredamento. La sua struttura superficiale è formata da un morbido strato di micro-pile che lo rende piacevole da accarezzare e che permette una stampa precisa e indelebile nel tempo.

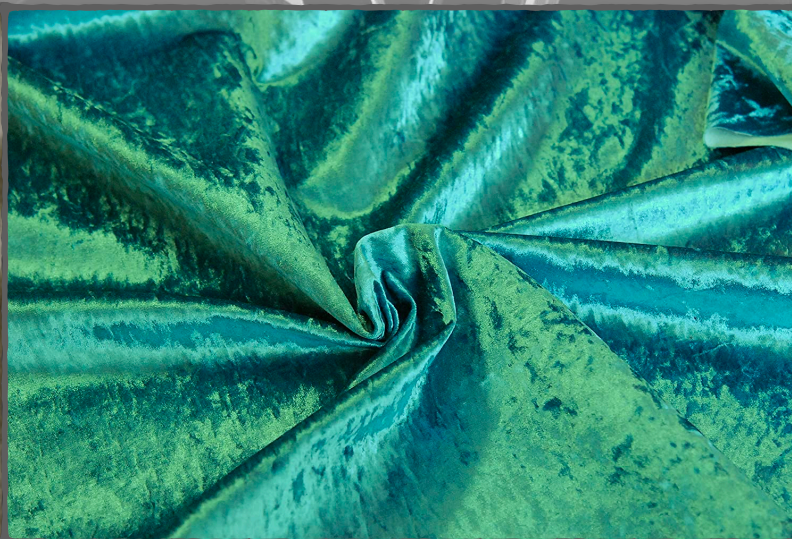



- Stampa Massima 1,39m, Peso 371gr/m<sup>2</sup>
- Velluto lucido dal denso pelo e grammatura pesante.
- 100% Poliestere



## STRUTTURA DEL TESSUTO

Il velluto è morbido ha una superficie in micro-pile spazzolata brillante (tipica del velluto) e rovescio che scivola morbidamente sulla pelle. La stoffa è leggermente più rigida degli altri velluti e mantiene le forme in modo naturale.

## DETTAGLIO DI STAMPA

Il velluto permette di raggiungere un livello di stampa di alto livello con dettagli e linee riportati in maniera accurata. La sua superficie riflette la luce e attira l'attenzione quando in movimento. La fase di pressatura potrebbe avvenire in diverse direzioni durante il processo di stampa coincidendo con una varietà di colori e brillantezza derivante dal punto di riflesso della luce.

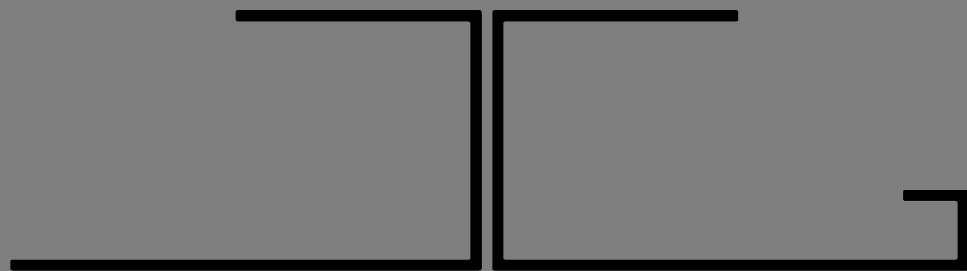

J A S O N   G I A N F R A N C H I

X

**accademia italiana**

---

A R T E   M O D A   D E S I G N